

# MEGALARM®

## Wiring Instructions

### MODEL MEGA 110

“The **MEGA** Protection”™

FROM  
**MEGATRONIX**

CALIFORNIA  
U.S.A.

This device complies with FCC Rules part 15. Operation is subject to the following two conditions, (1) This device may not cause harmful interference and, (2) This device must accept any interference that may be received, including interference that may cause undesired operation.

The manufacturer is not responsible for any radio or TV interference caused by unauthorized modifications to this equipment. Such modifications could void the user's authority to operate the equipment.

## INDEX

INSTALLATION INSTRUCTIONS .....	1
TOOLS REQUIRED .....	1
INSTALLATION: .....	1
MOUNTING THE SIREN UNIT .....	1
DECALS .....	1
WIRING .....	2
9-WIRE HARNESS .....	2
BLACK WIRE-SYSTEM GROUND .....	2
RED WIRE-SYSTEM POWER (+12V CONSTANT) .....	2
BLUE WIRE-GROUND TRIGGER INPUT .....	2
WHITE WIRE- FLASHING LIGHT OUTPUT (+12V) .....	2
ORANGE WIRE-500mA GROUND OUTPUT WHEN ARMED .....	3
PINK WIRE - LED Status .....	3
Gray Wire - Override/Valet Switch .....	3
Green Wire / Light Blue Wire .....	4
3-WIRE "NEGATIVE TRIGGER" Power Lock System .....	4
3-WIRE "Positive TRIGGER" Power Lock System .....	4
5-WIRE "Polarity Reversing" Power Lock System .....	5
Install New Door Lock Motors: .....	5
BLACK THIN WIRE-RF ANTENNA .....	5
PROGRAMING AND ADJUSTMENT .....	6
PROGRAMMING THE TRANSMITTER CODES .....	6
ENTER THE PROGRAMMING MODE .....	6
PROGRAMMING THE TRANSMITTER .....	6
Wiring Diagram Overview .....	7

## INSTALLATION INSTRUCTIONS

### TOOLS REQUIRED

Wire Crimper Electric Drill  
Wire Stripper 3/16" Drill Bit  
Pliers Phillips Screwdriver  
Voltmeter Electronic Tape

### INSTALLATION:

**CAUTION:** Do not connect the wire harness to module until all wiring to vehicle is complete.

#### A. MOUNTING THE SIREN UNIT

1. In the engine compartment, place the siren in a location suitable for best sound result. Be careful not to mount the unit near exhaust manifolds or other "hot" equipment and moisture area. **NOTE:** Preferred siren position is facing forward (Towards front of the vehicle). Siren **SHOULD NOT** be face up.
2. Mark and drill two 3/16" holes to screw on the mounting bracket. With the screws and lock washers provided, mount the bracket to the vehicle.
3. Mount the siren to the bracket with the bolts, washers and lock washers provided. Adjust the siren angle and tighten the bolts.

#### B. DECALS

Peel the decals from the paper backing and apply them to the inside of your vehicle's window. These are effective deterrents to thieves.

## WIRING

Keep wiring away from moving engine parts, exhaust pipes and high tension cables. Tape wires where they pull through holes on the firewall and guard against sharp edges that may damage wires and cause a short circuit.

### A. 9-WIRE HARNESS

#### 1. BLACK WIRE-SYSTEM GROUND

This is the main ground connection of the alarm module. Make this connection to a solid section of the vehicle frame. Do not connect this wire to any existing ground wires supplied by the factory wire loom. The connection of this wire is recommended to be made first.

#### 2. RED WIRE-SYSTEM POWER (+12V CONSTANT)

The red wire supplies power to the system. If you plan to program the alarm with current sensing, this connection must be made at the permanent +12 Volt live point of the fuse controlling the interior courtesy light of the vehicle. When 12 volts is first applied to the Red wire, the system will enter self diagnostic and code learning mode.

#### 3. BLUE WIRE-GROUND TRIGGER INPUT

This wire is the ground trigger input wire for additional hood/trunk pin switches and additional ground output sensors such as microwave sensors. This wire may also be connected to negative door pin switches.

#### 4. WHITE WIRE- FLASHING LIGHT OUTPUT (+12V)

When the alarm is triggered, this wire provides positive (+12V) pulsating output for parking lights. This wire must be connected to the positive wire of the parking lights.

## 5. ORANGE WIRE-500MA GROUND OUTPUT WHEN ARMED

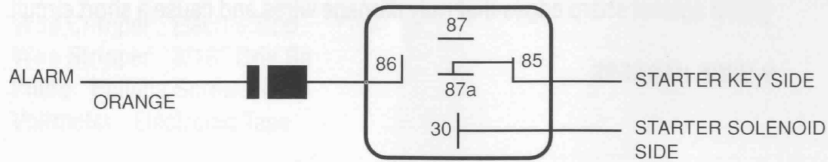

This wire will become grounded when the alarm is armed. The current capacity of this wire is 500mA. The connection of this orange wire should be to pin #86 of the optional kill relay or other accessories that require ground to activate, like LED, door lock module, window roll-up, etc.

## 6. PINK WIRE - LED STATUS

This is the LED status indicator output. Connect the "PINK" wire of the alarm to the pink wire of LED indicator, and connect the BLACK wire of the LED indicator to a chassis ground, using the terminal provided

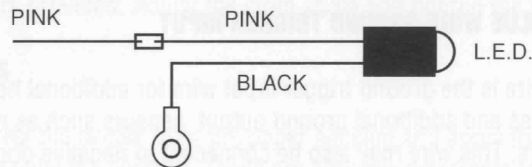

## 7. GRAY WIRE - OVERRIDE/VALET SWITCH

Mount the override/valet switch in a hidden but accessible location, on to a flat surface. Connect the gray wire of the alarm to the gray wire of the valet/override switch, and connect the yellow wire of the valet switch to a switched ignition (+12 v)

## 8. GREEN WIRE / LIGHT BLUE WIRE - Optional Doorlock Interface

The green wire produces a negative pulse for lock, and the light blue wire a negative pulse for unlocking the doors. The doorlock interface needed will depend upon the type of power doorlocks the vehicle has. Note: If the vehicle does not have existing power doorlocks Power doorlocks may be added to the vehicle. This will allow the alarm only to operate the doorlocks. The vast majority of power doorlocks are found as three systems types:

- 3 wire negative trigger
- 3 wire positive trigger,
- 5 wire polarity reversing.

### 3-WIRE "NEGATIVE TRIGGER" POWER LOCK SYSTEM

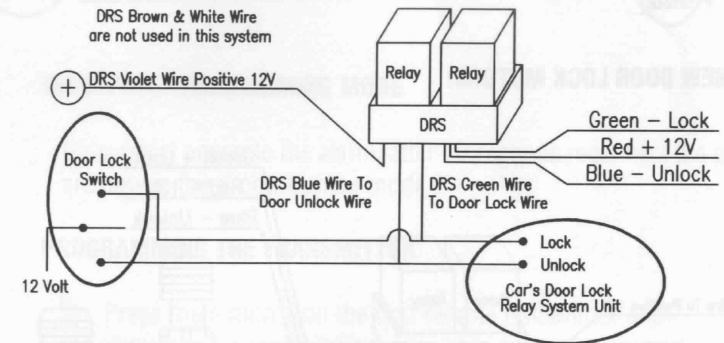

### 3-WIRE "POSITIVE TRIGGER" POWER LOCK SYSTEM

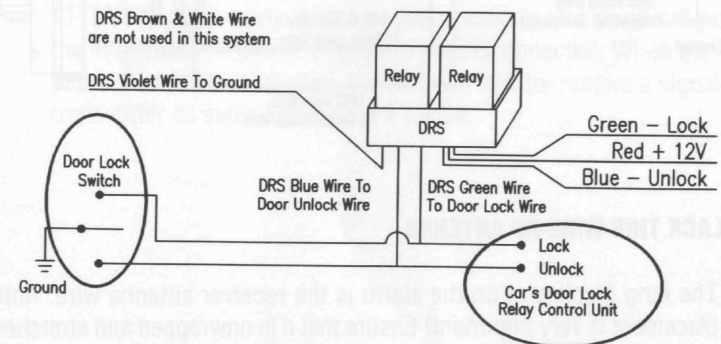

## 5-WIRE "POLARITY REVERSING" POWER LOCK SYSTEM

- i Lock the doors with the door lock switch. If the test light pulses on, record the LOCK WIRE color and cut the wire.
- ii Unlock the doors with the door lock switch. If the test light pulses on, record the UNLOCK WIRE color and cut the wire.

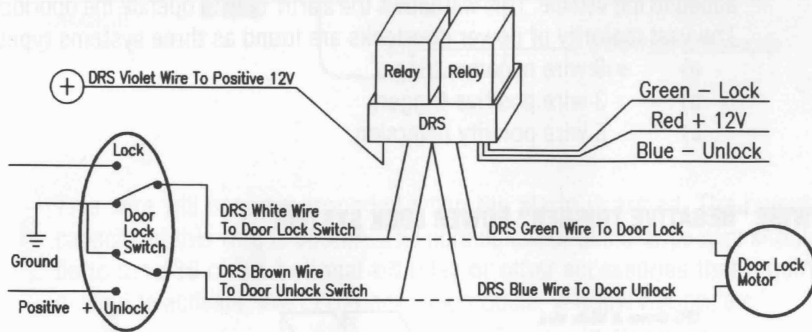

### INSTALL NEW DOOR LOCK MOTORS:

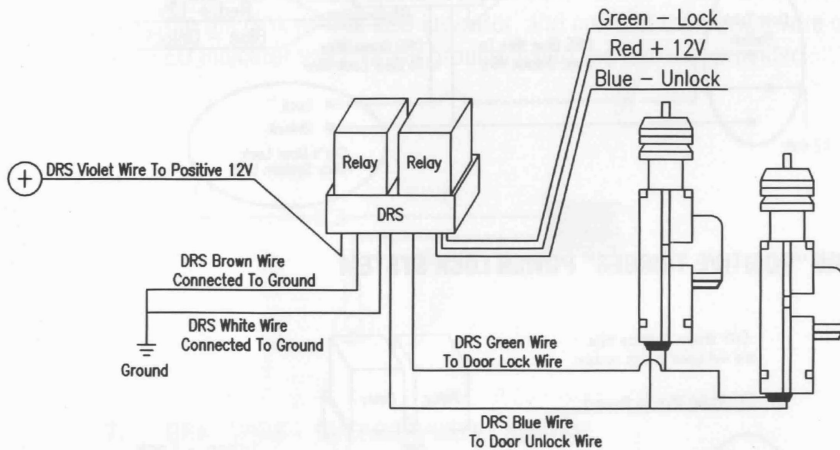

## B. BLACK THIN WIRE-RF ANTENNA

The long black wire on the alarm is the receiver antenna wire. Antenna placement is very important! Ensure that it is unwrapped and stretched out with the last 6" straight and keep it away from large metal objects or chassis for best reception.

## PROGRAMING AND ADJUSTMENT

### A. PROGRAMMING THE TRANSMITTER CODES

The transmitters supplied with this alarm system have been randomly coded. The alarm system does not know what the transmitter code is. After all wiring is completed, the final installation step is to teach the alarm system the transmitter code.

Programming transmitters	Programming confirmation
Press first transmitter's button I	One chirp from the siren
Press second transmitter's (optional) button I Within 5 seconds after programming first transmitter	One chirp from the siren

#### 1. ENTER THE PROGRAMMING MODE

Disconnect power to the alarm, after 10 seconds reconnect the power. You are now in the programming mode.

#### 2. PROGRAMMING THE TRANSMITTER

- a) Press the button 1 on the first remote transmitter until the alarm gives a confirmation chirp. It is now programmed.
  - b) Within 5 seconds after the first transmitter is programmed, press button 1 on the second remote transmitter until the alarm gives a confirmation chirp.
- ATTENTION!** The code learning system used in this alarm will not retain the information if power or ground are disconnected. When the red power wire is re-connected, the unit will wait to receive a signal from the transmitter as explained in step 2 above.

## WIRING DIAGRAM OVERVIEW

### Green Wire Loop-Current Sensing

Uncut: When the security system is armed, current sensing can detect an electrical current spike from the vehicle's battery and trigger the security system.

Cut: The Current Sensing feature will not operate.

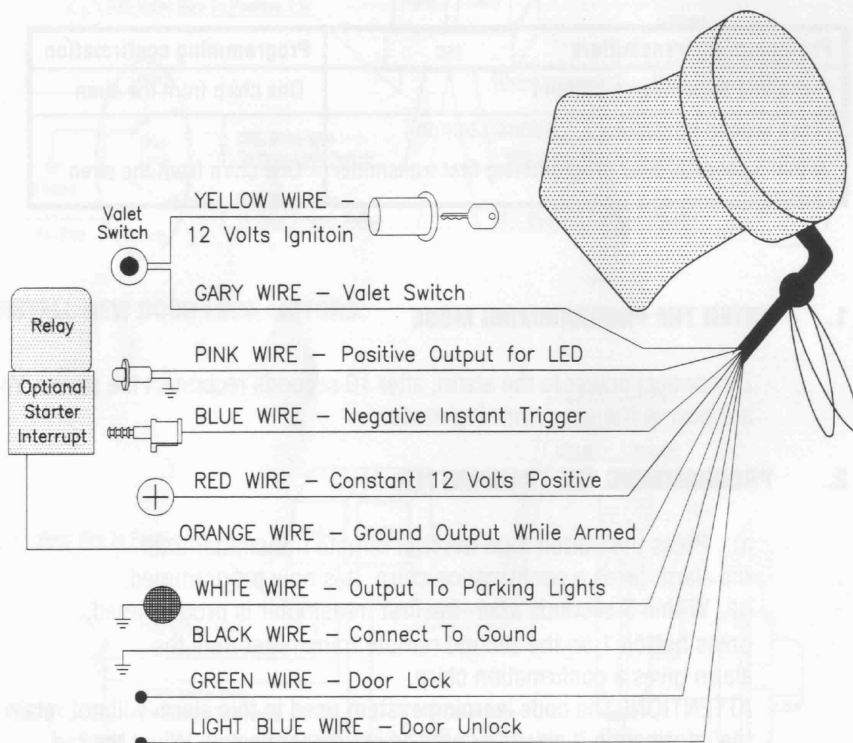

White Wire Loop -3 Minute  
Current Sensing Delay  
Cut: The Current Sensing  
feature can trigger the alarm as  
soon as it is fully armed  
Uncut: This feature will wait 3  
Minutes after arming before it  
can trigger the alarm.